



Interscan Corporation

Instruction Manual

LD Series Continuous Monitoring System

Table of Contents

<u>Introduction</u>	<u>1</u>
1.1 Component Check	1
1.2 System Description	1
1.3 Instrument Configuration.....	2
<u>Installation</u>	<u>3</u>
2.1 Wall Mounting.....	3
2.2 Plumbing The System.....	4
2.2.1 Enclosure Fittings and Connections	4
2.2.2 Balston Coalescer Filter (Optional).....	5
2.3 Electrical Connections.....	6
2.3.1 AC Line Cord.....	6
2.3.2 Analog Voltage Output	6
2.3.3 4-20 mA Current Output	6
2.3.4 Alarm Relay Contacts.....	6
2.4 Component Installation / Setup	9
2.4.1 Beacon-Ray Light or Strobe Light (Optional)	9
2.4.2 Vibratory Horn (Optional).....	9
2.4.3 Sonalert Horn (Optional).....	9
2.4.4 Power Off Alarm (Optional).....	9
<u>Quick Start – Basic Functions and Features</u>	<u>11</u>
3.1 Front Panel Controls and Indicators.....	11
3.2 Other Components.....	13
3.2.1 Gas Sensor	13
3.2.2 Sample Pump.....	13
3.2.3 Visual Alarm (Optional).....	13
3.2.4 Audible Alarm (Optional)	14
3.2.5 158LD Interference Scrubber (optional).....	14
3.2.6 Enclosure Heater (Optional)	14
3.3 Initial Start-up.....	14
3.4 Zeroing The Instrument.....	15
3.5 Sampling.....	15
<u>Advanced System Functions</u>	<u>16</u>

4.1	Programming Alarm Setpoints (Optional Feature)	16
4.1.1	<i>Checking Alarm Set-Points</i>	16
4.1.2	<i>Changing Alarm Setpoints</i>	17
4.2	Filter Clog Indication (Optional Feature)	17
4.3	Zero Procedure	17
4.4	Auto Zero (Optional)	18
4.4.1	<i>Auto Zero Function</i>	18
4.4.2	<i>Zero Fault Indication</i>	19
4.5	Sensor Protection Circuit (EtO Units Only).....	19
4.6	Custom Features	19
 <u>Sensor Calibration</u>		<u>20</u>
5.1	Introduction	20
5.2	Calibration Gas Standards	21
5.2.1	<i>Gas Blends In Cylinders</i>	21
5.2.1	<i>Permeation Devices</i>	21
5.3	Sample Bag.....	21
5.4	Calibration Procedure	22
5.5	Electronic Calibration Service (ECS).....	22
 <u>Maintenance</u>		<u>24</u>
6.1	Inlet Particulate Filter	24
6.2	Sensor Maintenance	25
6.2.1	<i>Sensor Weight</i>	25
6.2.2	<i>Sensor Removal</i>	25
6.2.3	<i>Sensor Refilling Procedure</i>	26
6.3	Zero Air Filter (Optional)	26
6.4	Interference Scrubber (optional)	27
 <u>Troubleshooting</u>		<u>28</u>
 <u>Warranty</u>		<u>30</u>
 <u>Return Authorization</u>		<u>31</u>
 <u>Parts List</u>		<u>32</u>

Introduction

1.1 Component Check

Check the contents list in each shipping container used to ship your monitor to ensure that all system accessories on the list(s) are included. Set all accessories aside until directed to install them later in the manual.

1.2 System Description

The Interscan LD Monitor consists of the Interscan gas sensor, sample draw pneumatics (where applicable), Digital meter/controllers, and various alarm output devices.

In basic operation sample air is drawn through the sensor, via a diaphragm sample pump and related pneumatics. The sensor's electrical output is sent via the sensor circuit board to the digital panel meter which processes the sensor outputs and produces a digital readout in PPM (parts per million). The maximum readout will depend on the range ordered but will usually be **50.0 ppm** for Ethylene Oxide monitors and **199.9 ppm** or **19.99 ppm** for all other gases. See section 1.3 for special range setup info if applicable.

When ordered accordingly, the meter/controller also compares the current gas level to preset alarm levels and activates alarm indicators and/or relay contacts when gas levels exceed these user set levels, in addition to outputting a 4-20 mA analog signal in proportion to the full scale range of the system. A 0-1V analog output signal is standard on all LD monitors.

ALL INTERSCAN MONITORS ARE CALIBRATED AT THE FACTORY PRIOR TO SHIPMENT.

Unless the **CAL** control is inadvertently changed, no calibration is required until the unit has seen considerable use.

1.3 Instrument Configuration

If your monitor contains special custom features, the operational details of those features are shown below:

GAS – Ethylene Oxide
FULL SCALE RANGE – 50.0 ppm

OPTIONAL FEATURES INCLUDED

AUDIBLE & VISUAL ALARMS – See sections 2.4, 3.2.3 & 3.2.4

SENSOR PROTECTION – See section 4.5

CUSTOM FEATUES

NONE

Section 2

Installation

2.1 Wall Mounting

The *Interscan* LD Monitoring System is housed in a NEMA 4X 16"W X 14"H X 8"D fiberglass enclosure. The enclosure is configured for wall mounting. The outer door is hinged on the bottom. For optimum access, enough room should be allowed to fully open the outer door. Secure the enclosure to the wall using 5/16 inch (7.937 mm) steel bolts. See figures 1-1 and 1-2 below for dimensional detail (only the furthest extruding exterior components are shown. Custom or special order features may not be pictured).

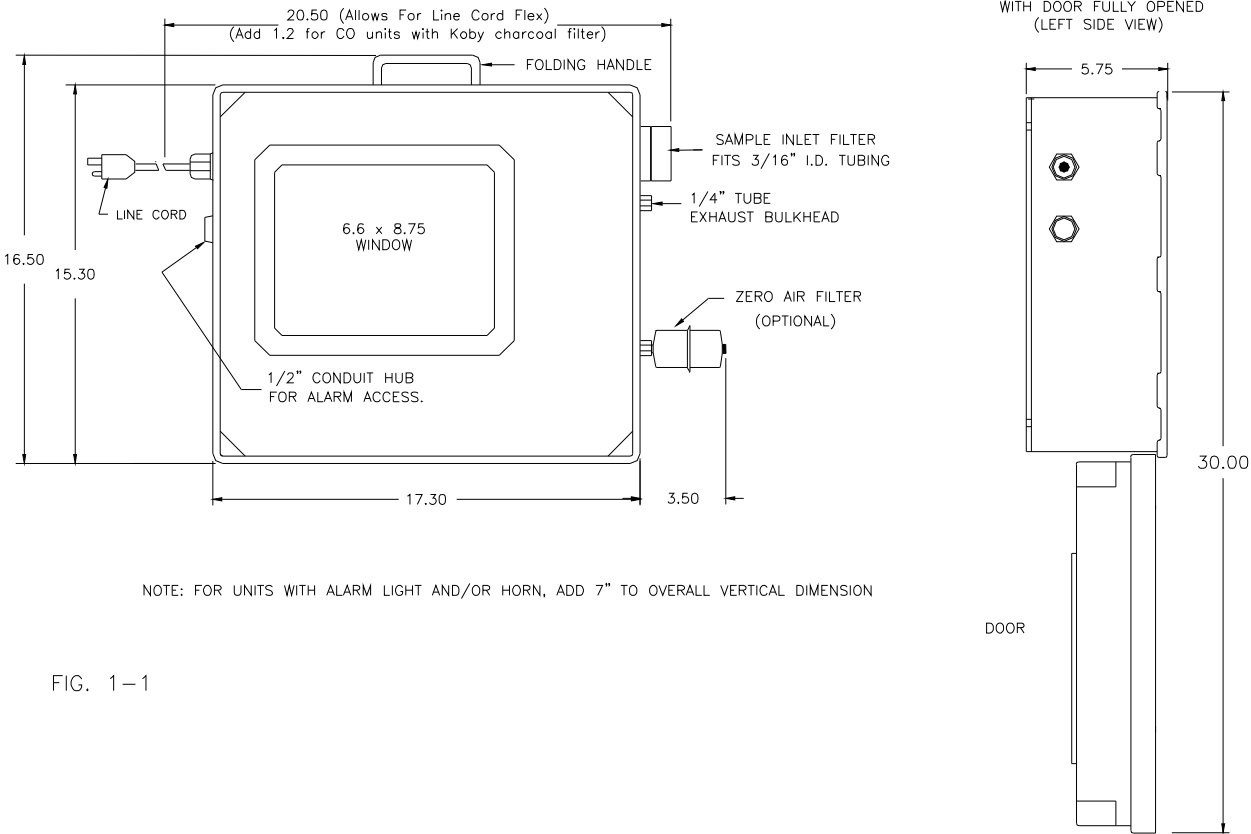

FIG. 1-1

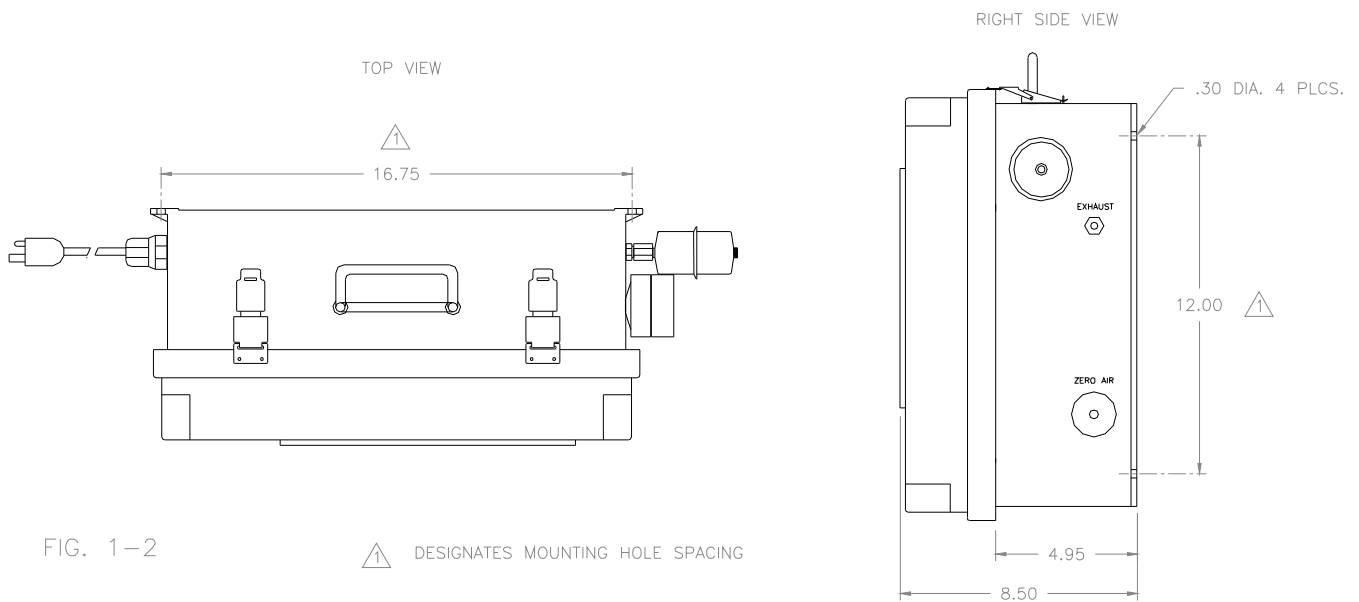

FIG. 1-2 △ DESIGNATES MOUNTING HOLE SPACING

2.2 Plumbing The System

2.2.1 ENCLOSURE FITTINGS AND CONNECTIONS

Sample air is drawn into and exhausted from the system via a series of pneumatic fittings located on the right side of the monitor enclosure. The locations, and purposes of the various fittings are detailed below.

- | | |
|----------------|--|
| INLET | Located on the upper right side of unit enclosure. Either a particulate filter or a bulkhead fitting through which sample air is drawn into the gas sensor. (See section 2.2.2 below). |
| EXHAUST | Located just below the inlet filter. A ¼" "push-in" style bulkhead fitting. This should be connected to an exhaust vent or manifold. Connect to this fitting by pushing tubing into the opening as far as possible and then gently pulling back on the tubing to ensure a tight fit. |

ZERO AIR

Optional Feature - Located on the lower right side of unit enclosure.. A charcoal filter attached to a bulkhead fitting through which zero air sample is drawn during Auto Zero cycles. No connection is necessary.

2.2.2 BALSTON COALESCER FILTER (OPTIONAL)

Units ordered with a Balston Coalescer Filter will be shipped with the filter unattached to the unit. The standard Millipore filter housing shown in Fig 1.2 will be replaced by an inlet bulkhead fitting to which the Balston filter will connect according to figure 2-1 below. The open port of the Balston housing screws on to the male threads of the fitting on the upper right side of the enclosure. Should the Balston housing ever need to be removed from the unit, unscrew the filter from the fitting in a counter-clockwise direction and reattach by screwing the filter onto the fitting in a clockwise direction.

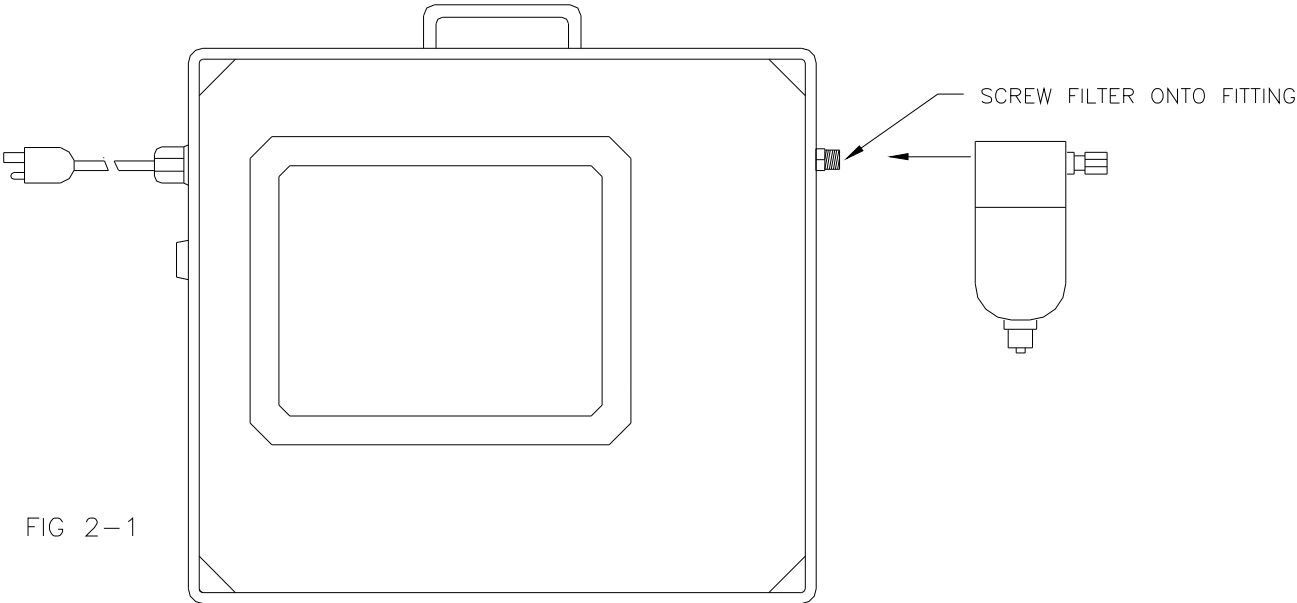

FIG 2-1

2.3 Electrical Connections

2.3.1 AC LINE CORD

Located along the left side of the unit enclosure. Plug the line cord into any standard wall socket. If no line cord is present, refer to section 1.3 for special instructions.

2.3.2 ANALOG VOLTAGE OUTPUT

An analog voltage output signal (usually 0-1V at full scale) is provided, calibrated for **0 V** when the meter display reads **0.0 ppm** and **1 V** when the meter reads full scale (see section 1.3). This output can be accessed at the **RELAY CONTACT AND ANALOG OUTPUT BOARD** which is located inside the unit on the left edge of the unit chassis. To access this board, open the unit enclosure, unscrew the 2 panel screws on the left side front panel and drop the panel. Loosen the 2 screws securing the blue Alarm Board cover and slide the cover to the right, exposing the output terminals. All output designations are clearly marked on the board as shown in Figure 2-1 below for output terminal designations.

2.3.3 4-20 MA CURRENT OUTPUT

An analog 4-20 mA current loop output signal is provided which is calibrated for **4 mA** when the meter display reads **0.0 ppm** and **20 mA** when the meter output reads full scale (see section 1.3). This output when provided can also be accessed at the **RELAY CONTACT AND ANALOG OUTPUT BOARD** as described in section 2.3.2 above. See Figure 2-1 below for output terminal designations.

2.3.4 ALARM RELAY CONTACTS

Form C Alarm relay contacts are provided and are also located at the **RELAY CONTACT AND ANALOG OUTPUT BOARD** as described in section 2.3.2 above. See Figure 2-1 below for output terminal designations in standard a configuration. A detailed verbal description of user output connections for the possible alarm output options is shown in tables 2-1 thru 2-3. The relay contacts are rated at 6 amps/120VAC, 6 amps/24VDC and 3 amps/240VAC.

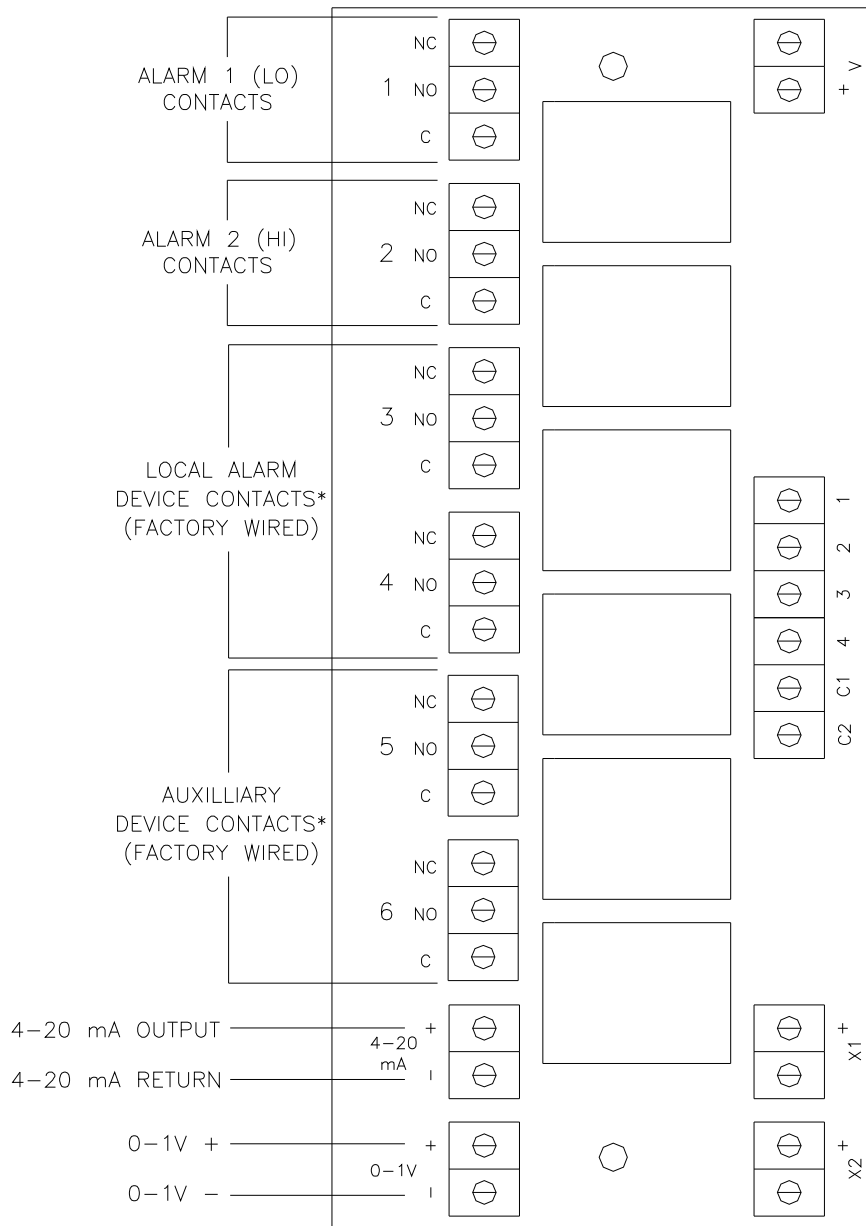

FIG 2-1

* MAY NOT BE PRESENT ON ALL UNITS.
 NO USER CONNECTIONS UNLESS SPECIFIED
 IN TABLE 2-2.

ALARM 1 OUTPUT	TERMINATION
ALARM 1 COMMON	1-C
ALARM 1 NORMALLY OPEN	1-NO
ALARM 1 NORMALLY CLOSED	1-NC
ALARM 2 OUTPUT	TERMINATION
ALARM 1 COMMON	2-C
ALARM 1 NORMALLY OPEN	2-NO
ALARM 1 NORMALLY CLOSED	2-NC

TABLE 2-1
(Unwired relay contact outputs – Standard LD configuration)

ALARM 1 OUTPUT	TERMINATION
24 VDC + OUTPUT	RELAY BOARD 1-NO
24 VDC COMMON	TB1-1
ALARM 2 OUTPUT	TERMINATION
24 VDC + OUTPUT	RELAY BOARD 2-NO
24 VDC COMMON	TB1-1

TABLE 2-2
(DC wired relay contact outputs – LDXX-DC configuration)

ALARM 1 OUTPUT	TERMINATION
24 VDC + OUTPUT	RELAY BOARD 1-NO
24 VDC COMMON	TB1-1
ACH OUTPUT	TB1-6 (Green Wire)
ACN OUTPUT	TB1-5 (White Wire)
ALARM 2 OUTPUT	TERMINATION
24 VDC + OUTPUT	RELAY BOARD 2-NO
24 VDC COMMON	TB1-1
ACH OUTPUT	TB1-3 (Green Stripe Wire)
ACN OUTPUT	TB1-5 (White Wire)

TABLE 2-3
(DC & AC wired relay contact outputs – LDXX-AC/DC configuration)

2.4 Component Installation / Setup

The following section details installation and setup for optional features that will only be present if ordered for your monitor.

2.4.1 BEACON-RAY LIGHT OR STROBE LIGHT (OPTIONAL)

The optional Beacon-ray light or strobe light mounts to the left side conduit hub on the top of the enclosure. Feed the light's wires through the hub and thread the light into the hub and tighten. Connect the two twisted white wires (for beacon-ray light) or black wires (for strobe light) to the same colored mating pair inside the unit. Unless ordered otherwise, mounted light devices will activate when the LO ALARM (Alarm 1) level is exceeded.

2.4.2 VIBRATORY HORN (OPTIONAL)

The optional vibratory horn mounts to the right side conduit hub on the top of the enclosure. Feed the horn's wires through the hub and thread the horn into the hub and tighten. Connect the two twisted black wires from the horn to the same colored mating pair inside the unit. Unless ordered otherwise, mounted horn devices will activate when the HI ALARM (Alarm 2) level is exceeded. See section for more on alarms and alarm levels.

2.4.3 SONALERT HORN (OPTIONAL)

The optional Sonalert horn is installed by INTERSCAN prior to shipping and requires no additional adjustments upon receipt. It is a black plastic disk mounted on the right side of the top of the monitor. Unless ordered otherwise, mounted horn devices will activate when the HI ALARM (Alarm 2) level is exceeded. See section for more on alarms and alarm levels.

2.4.4 POWER OFF ALARM (OPTIONAL)

Units equipped with a POWER OFF ALARM feature will contain either or all of a set of relay contacts (see table 2-2 for terminal locations if provided), and/or an audible alarm that will be activated whenever power to the unit is lost. The audible alarm includes an inhibit switch on the front panel labeled **P.O. ALARM / OFF**. The monitor is shipped with this switch in the **OFF** position. After AC power has been connected, set this switch to **P.O. ALARM**. The audible alarm is powered

by a 9 volt alkaline battery. The alarm should be checked every few months to verify the battery condition supplies an adequate alarm.

Section 3

Quick Start – Basic Functions and Features

This section gives a brief overview of the system’s most basic functions and components. A full reading of the manual is recommended for a thorough understanding of all unit functions.

3.1 Front Panel Controls and Indicators

Controls listed in Alphabetical order. Figure 3-1 below shows the location of the front panel components.

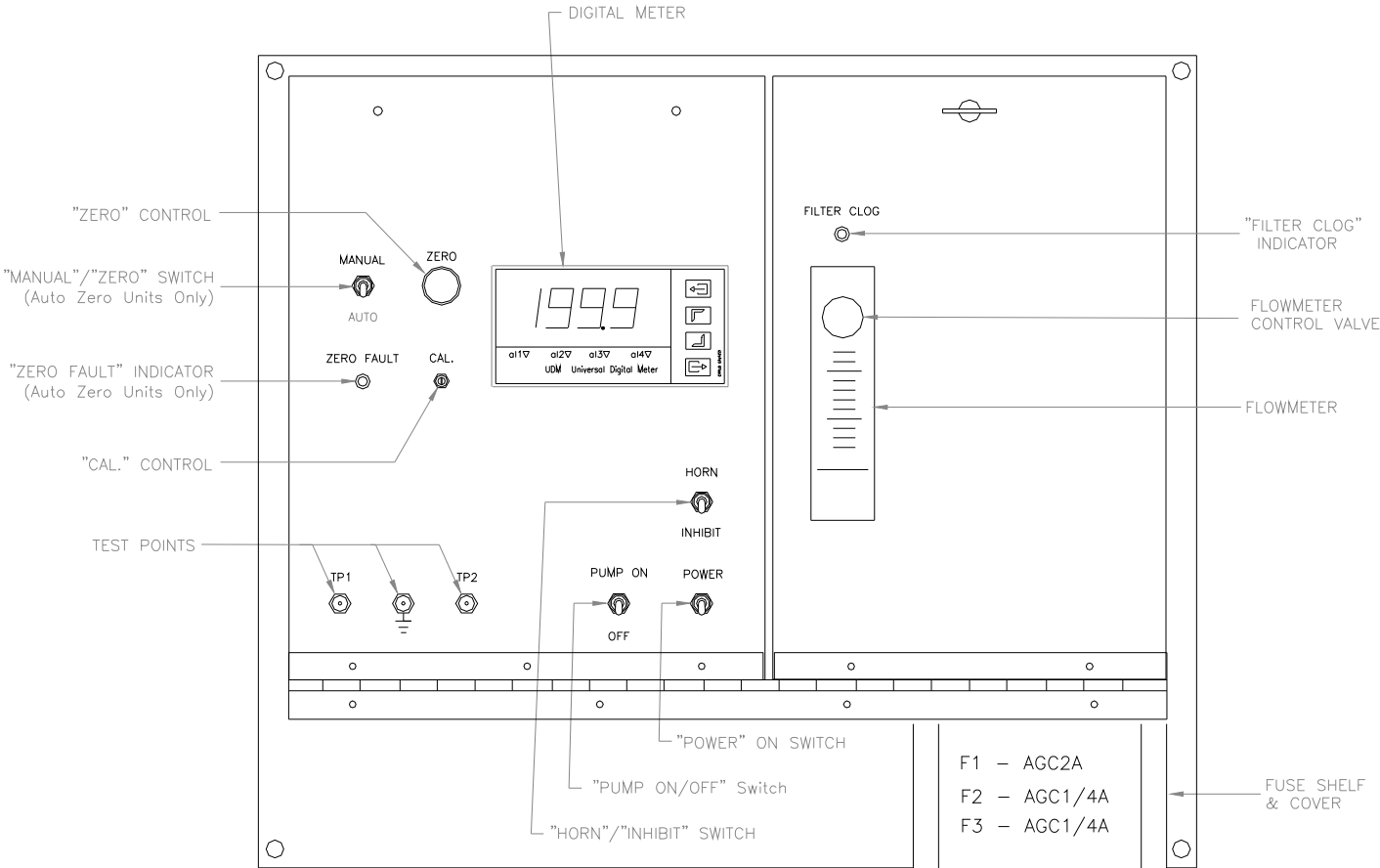

FIG. 3-1

Designation

Function

CAL CONTROL:	A 10-Turn flat blade screw type potentiometer. Adjusts the meter to correspond to the concentration of the calibration gas used when calibrating the instrument. This control should ONLY be adjusted when performing unit calibration. See section 5 for more on calibration.
DIGITAL METER:	Digital display indicator/controller. Displays gas concentration in parts-per million (ppm) unless alternate units are specified. Provides for user adjustability of 2 alarm set points and controls the alarm relays and indicators. An LED indicates which alarm point has been exceeded, 1 (low alarm) or 2 (high alarm). PPM display will change color upon alarm level activation – Orange=Lo Alarm, Red=Hi Alarm. Outputs a 4-20 mA analog signal where 4 mA corresponds to 0.0 ppm and 20 mA to the unit's full scale range (see section 1.3).
FILTER CLOG INDICATOR:	Optional Feature. Red L.E.D. indicator. Lights whenever the flow rate drops below a factory set level as a result of an inlet filter blockage. See section 4.3 for more on this feature.
FLOWMETER:	A sample flow regulating device. Measures and controls gas sample through the sensor. Turning the flowmeter control valve clockwise decreases flow-rate while turning it counter-clockwise increases the flow-rate. Proper sampling flow rate for each unit is indicated on a yellow sticker next to the flowmeter.
MANUAL ZERO/ AUTO ZERO SWITCH:	Optional Feature. Toggle switch. Enables the AUTO ZERO circuit in AUTO position and disables the circuit in MANUAL Position. See section 4.4 for more on this feature.
POWER ON SWITCH:	Toggle switch. Controls power to the monitor in the up position.
PUMP ON/OFF SWITCH:	Toggle switch. Switches the sample pump ON (SAMPLE) or OFF (ZERO). Disables alarm relays and indicators in the OFF (ZERO) position.

TP1 & TP2	Test point terminals for measuring circuit voltages. Used for troubleshooting and for electronic calibration. A GROUND test point is also provided.
ZERO CONTROL:	10-Turn potentiometer. Used to compensate for sensor background current and adjust meter reading to 0.0 ppm during the Manual Zero procedure. Also allows for manual simulation of sensor response during ECS calibration.
ZERO FAULT	Optional Feature L.E.D. indicator. Lights when the Auto Zero correction limit has been exceeded. See section 4.4 for more on this feature.

3.2 Other Components

3.2.1 GAS SENSOR

Black cylindrical device located inside the unit behind the right side flowmeter panel. Reacts with EtO when present in the sample stream, producing an electric current that is sent to the Digital meter and displayed as a PPM value.

3.2.2 SAMPLE PUMP

Located below the sensor behind the right side flowmeter panel. The diaphragm pump pulls sample air through the sensor and flowmeter and exhausts the air through the EXHAUST fitting on the right side of the enclosure.

3.2.3 VISUAL ALARM (OPTIONAL)

Either a red rotating beacon-ray light or a blue strobe light depending on the option selected. Located on the top of the enclosure on the left side. When provided, the visual alarm will be activated when the gas concentration exceeds the preset ALARM 1 (lo alarm) level. The visual alarm will NOT activate when the pump is off (SAMPLE / ZERO switch in ZERO position).

3.2.4 AUDIBLE ALARM (OPTIONAL)

Either a vibratory horn or a piezo style horn depending on the option selected. Located on the top of the enclosure on the right side. When provided, the audible alarm will be activated when the gas concentration exceeds the preset ALARM 2 (Hi alarm) level. The audible alarm will NOT activate when the pump is off (SAMPLE / ZERO switch in ZERO position).

3.2.5 158LD INTERFERENCE SCRUBBER (OPTIONAL)

The #158LD Interference Scrubber is provided for use in installations where interference gases may be present. An interference gas is one that can cause a false response in the EtO sensor that can result in false readings and alarms. Use the scrubber when you suspect an interference problem. The scrubber attaches to the inlet filter port via the clear plastic tubing connected to one end of the scrubber. See section 6.4 for information on scrubber maintenance.

3.2.6 ENCLOSURE HEATER (OPTIONAL)

Units provided with heated enclosure capability will have a self regulating strip heater element located below the front panel on the rear chassis. The heater element is a 120W silicon rubber radiant heater that is self regulated and will turn on below 40° F. The heater is controlled by its own fuse (F3 – AGC1.5A). In some units, 2 of these heaters will be utilized in which case F3 will be a AGC2A fuse.

3.3 Initial Start-up

Once all installation has been completed, the monitor is ready for power-up. Set all front panel switches to their down positions (**if the unit is equipped with the AUTO ZERO feature, be sure the AUTO/MANUAL switch is set to the MANUAL position on startup**). Turn power on by switching the **POWER ON** switch to the up position. You will likely notice a high positive or negative PPM reading on the panel meter. This is normal and is part of the sensor stabilization after prolonged periods without power. The sensors should be allowed to stabilize for 24 hours prior to initial operation.

Any time the system has been powered down or the sensor has been disconnected (off bias) for any length of time, it is recommended that upon reconnecting the sensor or re-applying the power, that the sensor be allowed to re-stabilize with the pump off until the ppm reading does not change

for several minutes before resuming normal sampling. This could take anywhere from a few minutes to several hours depending on how long the sensor was off bias.

3.4 Zeroing The Instrument

All *Interscan* sensors exhibit a slight amount of output even when not exposed to gas or when they are exposed to true “zero” air (a sample free of any sensor reactive gases). This output (called background current) can also fluctuate due to changes in temperature and sensor aging. If not compensated for, the background current would result in positive or negative display readings even though no gas was present. To compensate for this phenomenon, the unit should be “zeroed” before use for a true “zero” display reading. The ZERO procedure entails drawing sample air through a scrubbing device or filter that eliminates all reactants that the sensor could respond to and adjusting the ZERO control for a true zero reading on the PPM display.

After the initial start-up 12 hour sensor stabilization period, the unit should be zeroed. Refer to section 4.3 for details on this procedure.

3.5 Sampling

To begin sampling by switching the SAMPLE / ZERO switch to **SAMPLE** and adjusting the flowmeter control valve for a flow rate of **0.50 lpm OR THE FLOW RATE INDICATED ON THE FLOW RATE STICKER NEXT TO THE FLOWMETER**. (For units equipped with **ccm** flowmeters, set the flow rate for the equivalent reading of **500 ccm**.)

If the AUTO ZERO feature is to be utilized, switch the AUTO/MANUAL switch to the AUTO position. See section 4.4 for more on AUTO ZERO.

Section 4

Advanced System Functions

4.1 Programming Alarm Setpoints (Optional Feature)

Refer to figure 4-1 below for the following sections.

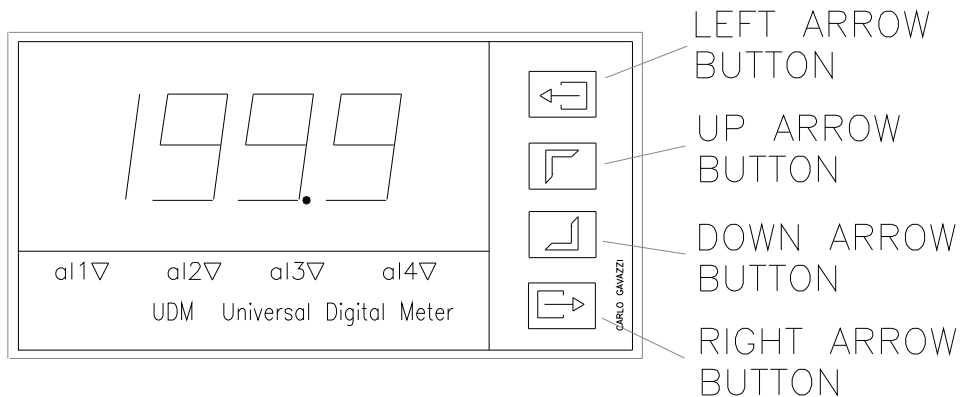

FIGURE 4-1

4.1.1 CHECKING ALARM SET-POINTS

NOTE: Alarm relays will not function when “Sample/Zero” switch is in “Zero” or pump off position. To test these relays, turn pump on. To set alarms, see Section 4.1.2.

Momentarily press the **up arrow** button on the panel meter. The display will show “**SP1**”. Press the **left arrow** button to display the current set point value for set point 1 (LO ALARM). Wait several seconds for the display to return to “**SP1**”.

Press the **up arrow** button to advance display to “**SP2**”. Press the **left arrow** button again to display current set point value for set point 2 (HI ALARM). The display will automatically return to the main display reading after a few seconds.

4.1.2 CHANGING ALARM SETPOINTS

Alarm set points for all Interscan monitors are factory set at **1/3 and 2/3 of the full scale range**. These values are arbitrary and for testing purposes only. Interscan does not recommend specific field values for alarm set points as proper values will depend on the application. The user is responsible for determining proper alarm set points for their application.

The alarms set points can be re-set to any desired level by following the simple procedure below.

Momentarily press the **up arrow** button on the panel meter. The display will show "**SP1**". Press and HOLD the **right arrow** button until the display changes to a numeric value. The left-most digit will be highlighted. Press the **left arrow** button successively to highlight the digit you wish to alter. Alter the digit by pressing the **up arrow button** to increase the value or the **down arrow** to decrease the value. Repeat this procedure for each digit as required. When satisfied with the value, press the **right arrow** button to lock the value into the memory. Display will return to "SP1".

Press the **up arrow** button to advance to "SP2" and repeat the entire procedure. When finished, allow the display to automatically return to the main display reading.

4.2 Filter Clog Indication (Optional Feature)

The FILTER CLOG L.E.D. indicator will light whenever there is a drop in flow rate caused by an inlet line restriction. This could be the result of a clogged inlet filter or a kink in the inlet tubing or other similar sample line restriction. When this indicator is lit, the inlet filter and tubing lines should be checked and maintained as described in section 6.1. If frequent or constant FILTER CLOG indications occur with no associated inlet blockage, it could be an indication of an improperly set FILTER CLOG vacuum switch. Contact the INTERSCAN service dept. if this should occur.

4.3 Zero Procedure

Zeroing of the ppm display is necessary from time to time to compensate for natural zero drift of the sensor output due to temperature fluctuations and sensor aging. The procedures for zeroing the system are described below.

Most monitors can be zeroed by merely adjusting the **ZERO** control for a reading of **0.0 ppm** on the meter display following the 24 hour start-up stabilization period. **For low range units (19.99 ppm full scale or less), and for all Ethylene Oxide, Formaldehyde and Hydrazine models**, the monitor should be zeroed with the pump on as described below.

Attach the *Interscan* C-12 Zero filter included in the original shipping contents to the inlet filter port using a short length of ¼" OD tubing. **If the 158LD interference scrubber is in use at the inlet port, either attach the C-12 filter to the end of the scrubber or TEMPORARILY replace the scrubber with the C-12 filter.**

Turn on the pump and adjust the flow rate to **0.5 lpm (500 ccm** on ccm flowmeters) **OR THE FLOW RATE INDICATED ON THE FLOW RATE STICKER NEXT TO THE FLOWMETER.** Allow several minutes for the reading to stabilize prior to making **ZERO** adjustments. Once the reading is stabilized, manually adjust the **ZERO** potentiometer knob until the display value reads **0.0 ppm** . Remove the C-12 filter from the inlet filter. **Be sure to remove the C-12 filter before resuming normal sampling as failure to do so will result in no sensor readings when gas is present. Re-attach the 158LD scrubber if utilized.**

4.4 Auto Zero (Optional)

4.4.1 AUTO ZERO FUNCTION

The AUTO ZERO feature allows for automatic zeroing of the system display to compensate for excessive sensor zero drift. This is usually incorporated in lower range units. The Auto Zero circuit will zero the ppm display in pre-set user programmed intervals. Setting the **Auto Zero / Manual Zero** switch to **Auto Zero** engages the Auto Zero circuit which will cycle the sensor between normal sampling and auto zeroing at a factory set interval of 2 minutes of zeroing every 4 hours. When in a zero cycle, a solenoid valve diverts the sample flow from the inlet fitting to the Zero air fitting and ambient air is drawn through a charcoal filter which scrubs out sensor reactant gases yielding a true zero sample. The circuit then analyzes the current sensor output and adjusts the display reading to **0.0 ppm** ($\pm 1\%$ of full scale range). After the zero cycle times out the monitor will switch back to normal sampling mode. The Auto Zero cycle will be disabled if the unit is in an alarm condition.

To disable the Auto Zero circuit, set the **Auto Zero / Manual Zero** switch to **Manual Zero**. This will reset the Auto Zero compensation circuit and a sudden change in the display value will likely occur. To compensate, manually zero the monitor according to the procedure described in section 4.3.

4.4.2 ZERO FAULT INDICATION

The Zero Fault indicator will light whenever the Auto Zero compensation limit has been exceeded. If over consecutive zero cycles the sensor output has drifted beyond a factory preset value, the Zero Fault indicator will light indicating that the sensor may need maintenance or replacement. WHEN A ZERO FAULT OCCURS, THE UNIT WILL REMAIN IN ZERO MODE FOR THE DURATION OF THE FAULT. NORMAL SAMPLING WILL NOT RESUME UNTIL THE FAULT IS MANUALLY CLEARED.

To clear the ZERO FAULT condition, cycle the **AUTO/MANUAL** switch to the **MANUAL** position. This resets the zero compensation and shuts off the fault indicator. At this point the unit should be MANUALLY ZEROED. To restart AUTO ZERO, simply set the **AUTO/MANUAL** switch back to **AUTO**.

4.5 Sensor Protection Circuit (Optional Feature)

To protect the sensor from exposure to high concentrations of the gas being monitored in Ethylene Oxide applications, the pump will automatically shut off when the ppm level measured reaches full scale (see section 1.3). This condition will latch and the pump will remain off until the ppm level drops below a factory set level of approximately 90% of full scale. Once the sensor output decays below this level, the pump will turn back on and normal sampling will resume. If the high gas concentration is still present, the sensor output will rise to the shutoff level and the pump will again be turned off. This on/off cycle will repeat until the source of the high gas concentration is eliminated. All alarms will continue to function while the pump is off in this condition.

4.6 Custom Features

If your unit is equipped with any custom features, they will be described in this section.

Section 5

Sensor Calibration

5.1 Introduction

All *Interscan* instruments are calibrated at the Factory prior to shipment. Unless the CAL. adjustment knob is inadvertently changed, there is no need to calibrate the monitor until it has seen considerable usage

There is no easy answer as to how often zeroing and calibration should be performed. This is strictly a function of the application. Sensor zeroing compensates for signal drift and sensor calibration compensates for any possible decrease in sensitivity. The primary cause of sensitivity decrease is excessive loss of water by evaporation due to time and temperature.

The instrument is calibrated by introducing a known concentration of gas and adjusting the CAL. control to the proper ppm level. As such, the analysis of the calibration gas must be accurate. The sources of gas standards include commercially available gas mixtures diluted with air or nitrogen in cylinders or permeation devices.

Interscan offers "Electronic Calibration Service" (ECS – See section 5.5), which permits the user to calibrate the instrument without the use of gas. Calibration is accomplished by quick and simple adjustments of the ZERO and CAL. controls using a digital voltmeter.

5.2 Calibration Gas Standards

5.2.1 GAS BLENDS IN CYLINDERS

Low concentration gas mixtures (in air or nitrogen) are available with few exceptions, in pressurized cylinders. The major concern in using commercially available mixes of active gases is reliability. The analysis results shown on the label are applicable only at the time the analysis was performed. Concentration stability with time varies widely as a function of the gas mix, its container, and the manufacturer. *Interscan* should be consulted for recommendations on commercially available gas mixtures.

5.2.1 PERMEATION DEVICES

An alternative calibration method is the use of permeation devices containing the gas liquefied under pressure. Permeation of the gas in nanogram-per-minute rates, permits the generation of a desired concentration in an air or nitrogen carrier.

Varying the temperature, flow rate, and emission rate characteristics gives a fairly wide range of gas concentrations. Many gases in a low ppm range are ideally suited to the permeation device technique. It is important to remember to keep the permeation device flow rate higher than the **0.50 liter/minute** rate required by the *Interscan* system.

Consult the permeation device manufacturer for complete operation and procedure information.

5.3 Sample Bag

Whatever the source of calibration standard, the recommended method of gas collection and delivery is via a proper sample bag, which is then attached to the calibration inlet. The calibration gas is drawn through the sensor by the sample pump.

Contact *Interscan* for recommendations on the type of sample bag to use.

5.4 Calibration Procedure

1. Perform the MANUAL ZERO procedure as detailed in section 4.3.
2. Turn on the sample pump and adjust the flowmeter control valve to the recommended flow rate of **0.50 lpm (500 ccm)**, **OR THE FLOW RATE INDICATED ON THE FLOW RATE STICKER NEXT TO THE FLOWMETER IF DIFFERENT.**
3. Fill the sample bag with the calibration standard, and attach it to the inlet fitting. This is best done by attaching a short length, 2 inches (50 mm) of 1/4 inch (6.350 mm) OD flexible tubing to the sample bag nipple, then attaching the tubing to the filter inlet or end of 158LD interference scrubber when utilized.
4. After an 8 - 9 minute delay, use the potentiometer adjustment tool supplied with the unit to adjust the CAL. potentiometer so that the meter display reads the same as the ppm value of the cal gas being used. Clockwise adjustments raise the reading while counter clockwise adjustments lower the reading.
5. Remove the sample bag and allow time for the meter reading to return to zero.

5.5 Electronic Calibration Service (ECS)

The factory recommended procedure for calibrating all *Interscan Corp.* sensors involves the use of calibration gas or permeation device. Besides being essential for calibration, having a known certified gas standard on hand allows the user to test the instrument at any time to verify that the sensors “really work”.

There will be times and circumstances in which calibration using calibration gas or permeation devices is inconvenient and/or impractical. For this reason Interscan Corp. developed the **Electronic Calibration Service (ECS)**.

ECS involves a “sensor rotation” regimen whereby a factory certified spare sensor is kept on hand to be rotated into the system when the original sensor is ready for re-certification. The original sensor is removed, the spare sensor is installed and the unit is calibrated according to ECS specifications that are detailed on the spare sensor’s ECS CERTIFICATE. The original sensor is then sent back to the factory for updated certification after which it becomes the new spare sensor. The calibration is a simple 2 step adjustment process that requires only an adjustment tool and a digital voltmeter.

NOTE: When stored under the proper conditions, the expected shelf life of an ECS spare sensor is 12 months. The sensor should be stored at room temperature and no less than 30% relative humidity. More extreme conditions can significantly shorten the shelf life of the ECS sensor.

The ECS program verifies the integrity of the sensor sensitivity only, and does not guarantee the operation of the entire system. Most importantly, the ECS program is not a substitute for basic system maintenance, nor does it check for malfunction of system components.

Section 6

Maintenance

6.1 Inlet Particulate Filter

Inlet filtering is needed to keep particulate matter from entering the sensor. The inlet filter is located on the upper, right side of the unit enclosure. Most units utilize a Millipore filter housing and Teflon element (shown in figures 1-1 and 1-2 in section 1. These filters need to be inspected and changed on a regular basis with frequency depending on the nature of the environment in which the system operates. Drops in flow rate below the nominal **0.50 lpm (500 ccm)** rate may indicate a clogged filter and as such, the flow rate should be checked from time to time to ensure that it is maintained at the nominal rate. The filter should be checked and changed if frequent upward adjustment is necessary to keep the flow rate at or above **0.50 lpm (500 ccm)** or when the optional FILTER CLOG indicator is lit. Periodic replacement on a field-determined time interval (for your particular installation) is the best approach. If regular maintenance checks reveal heavily packed or clogged filters, more frequent inspection is indicated.

To change the Millipore filter element, unscrew the outer section of the round filter housing attached to enclosure revealing the filter element disc. If the disc is noticeably dirty or clogged, replace it with a new one. It is also a good idea to inspect the inside of the inlet port and clean as necessary. Insert the new filter element with the shiny side facing in toward the fixed part of the housing. Carefully screw the outer housing back on to the inner housing making sure the element stay flush against the inner housing surface.

Carbon Monoxide monitors typically use Koby charcoal filters instead of the Millipore filter. These filters do not require any maintenance but should be replaced once a year if used continuously. Contact the INTERSCAN service dept for Koby filter replacement assistance.

In cases where the sample is wet, a Balston coalescer filter will be employed. The filter elements of these filter assemblies can be changed by unscrewing the bowl retainer ring on the bottom of the filter, removing the bowl from the assembly, unscrewing the element retainer ring below the element and replacing the element with a new one. Re-assemble the filter in the reverse order.

6.2 Sensor Maintenance

Sensors in continuous monitoring systems under continuous operation lose water by evaporation. Optimum performance requires that this water be replaced periodically. This is done by injecting **distilled** or **deionized** water into the sensor via the red fill plug hole, using the plastic 10 ml syringe provided.

6.2.1 SENSOR WEIGHT

The amount of water needed for normal operation of most sensors is not critical in most cases but it is advisable **not** to exceed a weight loss of more than 50 grams (25 grams for Hydrazine and Formaldehyde sensors), or a weight gain of more than 10 grams (some sensor requirements may differ. See the sticker on the side of the sensor body for limits specific to the sensor). It is recommended that the sensor be weighed AT LEAST every 6 weeks.

NOTE: HYDRAZINE sensors are significantly more susceptible to dehydration weight loss than other sensors and as such, should be checked at a recommended rate of once every 2 weeks and should be REFURBISHED at the factory every quarter. This will require having a spare sensor on hand to swap with the sensor to be sent to the factory for refurbishment. See section 5.5 above.

6.2.2 SENSOR REMOVAL

To remove the sensor, turn power to the unit off and disconnect the electrical connections to the sensor (1 blue wire and 1 white/blue stripe wire). Disconnect the tubing from the sensor ports by pushing in on the dark gray collar on the sensor elbow fittings while simultaneously pulling out on the tubing. Unscrew the 2 screws holding the sensor base to the slide in bracket and slide the sensor away from the bracket.

For Formaldehyde and Hydrazine sensors, remove the sensor body from the sensor base by loosening the clamp screw and lifting the sensor body away from the base. **NOTE: DO NOT REMOVE ANTHING ELSE FROM THE SENSOR**

6.2.3 SENSOR REFILLING PROCEDURE

1. Using the 10 ml syringe supplied, restore the original sensor weight by injecting an amount of **distilled** or **de-ionized** water in ml equal to the weight loss in grams via the red fill plug. (10g weight loss means add 10ml of water). **DO NOT OVERFILL !** Always inject the water **SLOWLY** and note if water drains out of the fill hole before the calculated amount is injected. If you notice water draining from the fill hole, STOP FILLING and replace the fill plug. Overfilling the sensor can cause electrolyte to leak into the sample tubing during sampling.

NOTE: HYDRAZINE sensors should typically have 25 to 30 ml of **distilled** or **deionized** water added every 2 weeks depending on actual weight loss. If more than 2 weeks has elapsed since the last maintenance on a HYDRAZINE sensor, it may not be possible to restore the sensor to its original weight. Only add as much water as the sensor can hold without draining.

If the sensor has gained weight up to 10g, no action is required. NEVER remove water from the sensor as this will remove electrolyte as well and damage the sensor. If weight gain exceeds 10g, contact the factory for instructions.

2. Re-install sensor. Assure that all electrical and pneumatic fittings are secure. The sensor should be allowed to stabilize for at least 12 hours with POWER ON.

6.3 Zero Air Filter (Optional)

Units equipped with the Auto Zero feature will include a blue Koby charcoal filter connected to the ZERO AIR inlet on the lower right side of the enclosure. This filter has a life expectancy of about 1 year under normal AUTO ZERO conditions (2 minutes of flow every 4 hours). The date of installation is tagged on the filter for replacement reference. We recommend filter replacement once per year. Filters can be ordered from INTERSCAN by contacting our service dept.

6.4 Interference Scrubber (optional)

The #158-LD scrubber is used in some installations where interference gases may be present. An interference gas is one that can cause a false response in the gas sensor. Known sources of interferences include steam sterilizers, ultrasonic baths, and floor strippers & waxes. One of the most troublesome interference gas sources is Isopropyl Alcohol (IPA). IPA, extensively used in areas where EtO is monitored, is a **MAJOR** interference to the EtO monitor. Sources include certain cleaning agents, perfumes and hand lotions. Frequent exposure to IPA results in sensor contamination, indicated by a permanent zero up-shift in the sensor readings, extremely slow sensor response & recovery, and/or very low PPM readings. **No satisfactory scrubber for IPA is yet available.** If IPA must be used in an area being monitored, shut OFF the instrument's sample pump before using IPA. Leave the pump off for 15 to 20 minutes after using IPA. Switch the sample pump back ON to resume monitoring.

The 158LD Scrubber if included is a cylindrical clear plastic tube containing violet pellets and when used is attached to the inlet filter port. As the scrubber ages and its effectiveness is depleted, the pellets contained inside will begin to change color. From their original violet color, the scrubber pellets change to a light brown then to a darker brown which later deepens to almost black. Even if all the pellets show the brown-black exterior, the scrubber may still retain high efficiency. Infrequent inspection requires the removal of ten pellets from a thoroughly mixed lot, breaking them open and examining their inner cores. If only two of these retain the violet core, the scrubber is only 75% efficient and should be replaced.

It is a good idea to check the scrubber pellets when doing routine sensor maintenance. When depleted, simply discard and replace with a new scrubber.

Section 7

Troubleshooting

A high percentage of service problems often result from little things you can find and fix yourself. Always consult with the INTERSCAN service department for problems not on this list or if suggested corrective actions fail to fix the problem. ALWAYS turn power off before working inside the unit.

Symptom	Corrective Action or Probable Cause
No power	<ul style="list-style-type: none"> • Check that power switch is on. • Turn power off and check main fuse (F1) located below the flowmeter/sensor panel on the right side. If fuse is blown, replace with AGC-2A and turn power back on. If fuse continues to blow, contact the <i>Interscan</i> Service Dept.
Can't achieve 0.50 LPM flow rate.	<ul style="list-style-type: none"> • Check inlet filter for blockage. • Check all tubing for kinks.
Liquid in flowmeter or tubing.	<ul style="list-style-type: none"> • Sensor has leaked electrolyte. Consult with Interscan service dept. for sensor, and affected component replacement.
No response to gas	<ul style="list-style-type: none"> • Check all sensor connectors for firm connections. • Check for solid connection of circuit board connector to circuit board (Sensor circuit board is located on the inside just above the panel meter). • Check that Cal/Span control is NOT turned all the way down (full counter-clockwise).

Symptom	Corrective Action or Probable Cause
Cannot Zero	<ul style="list-style-type: none"> • Check the Bias voltage with a DVM at TP1 on the front panel. This voltage should be within the range shown in table 7-1 below for the type of sensor being used. If not within the range shown, contact the <i>Interscan</i> service dept. • Sensor may be bad. Contact the <i>Interscan</i> service dept.

TABLE 7-1 BIAS VOLTAGES

<u>GAS</u>	<u>BIAS VOLTAGE RANGE</u>
CO	665 - 687 mV
EtO	390 - 410 mV
HCl / HCN	480 - 500 mV
MMH / HZ	240 - 260 mV
HCHO	190 - 210 mV
SO ₂	540 - 560 mV
Cl ₂	-790 - -810 mV
ClO ₂	-790 - -810 mV
NO ₂	-790 - -810 mV
NO / NO _x	340 - 360 mV
H ₂ S	490 - 510 mV

Section 8

Warranty

Interscan Corporation warrants continuous monitoring systems of its manufacture (sensors, batteries, fuses, lamps, tubing, fittings, filters, and scrubbers excepted) to be free from defects in material and workmanship for a period of one year from date of shipment.

Interscan Corporation warrants sensors of its manufacture to be free from defects in material and workmanship for a period of six months from date of shipment.

Interscan Corporation's sole obligation under this warranty is limited to repairing or replacing, at its option, any item covered under this warranty, when such item is returned intact, prepaid to the factory (or designated service center).

This warranty does not apply to any of our products which have been repaired or altered by unauthorized persons, or which have been subject to misuse, negligence, or accident, incorrect wiring by others, installation or use not in accordance with instructions furnished by the manufacturer, or which have had the serial numbers altered, effaced or removed. The sensors are factory sealed and must not be opened or modified in the field for the warranty to remain in effect. This warranty is in lieu of all other warranties, whether expressed or implied.

This warranty does not apply to any of our products, that have had any program and/or software changes incurred, without written authorization from *Interscan Corporation*.

Additionally, warranty on any component shall not exceed the manufacturer's warranty given to *Interscan Corporation*.

Return Authorization

All units being returned for repair or for sensor replacement require return authorization. Contact the Interscan Service dept. to request an RMA number.

Toll-Free **800-458-6153 x139**
Alternate **818-882-2331 x139**
FAX **818-341-0642**
e-mail: service@gasdetection.com

Section 10

Parts List

Resistors, Variable

Zero	50K, 10-Turn, 3540-1-503/Bourns
Cal	10K, 25-Turn, 3057J-1-103M/Bourns

Switches

Power	7101/C&K
Sample/Zero	MTA206N/Alco

Miscellaneous, Standard

Meter	UDM40-LSX-AV-R5-H/Carlo Gavazzi
Power Supply, 15V	PS1515.1/Interscan
Power Supply, 24V	HB24-1.2-A
Fuse, F1	AGC-2A/Buss
Fuse, F2	AGC-1/4A/Buss
TB1, Terminal Strip	12-140/Cinch
Line Filter	5VK1/Corcom
Connector, Circuit Boards	50-20SN-10/Cinch
SE1 (Sensor)	Model No. 120-LD /Interscan
Fitting, Sensor	I480821S/John Guest
Bulkhead, Inlet	PI1208S/John Guest
Bulkhead, Outlet	PI1208S/John Guest
Fitting, Rotameter	PI480821S/John Guest, Thogus Tee
Filter, Inlet	SX0004700/Millipore

Rotameter	11220VOB-S/Matheson
Fuse Holder	3998/Buss
Pump	BP202-1/Binaca
Test Point	1507-103/Smith
Relay, Alarm 1 & 2	LZ24H/Takamisawa

Miscellaneous, Optional

Vacuum Switch	MPL502-26in./Micro Pneumatic
Fitting, Vacuum Switch	70-4/Jaco
Horn, Sonalert	A1382K/Projects Unlimited
Strobe Light, Blue	490S-120-Blue/Micro Strobe
Beacon Light	121S/Vitalite
Vibratory Horn	350-120/Federal Signal
Relay, Zero Air Valve	LZ12H/Takamisawa
Solenoid Valve, Auto Zero	B14DK1075, AC120/Skinner
Fitting, Zero Air	4BCF2/Gyrolok
Filter, Zero Air	1125-SS-2/Koby
Enclosure Heater	3654K22/McMaster Carr
Pump Recycling Timer	GT3W-A11AF20N/Idec